

Liquids to Value



PandaPLUS 1000

From the world leader
in high pressure
homogenization:
absolute quality
and reliability
with advanced
technical solutions
for any process need.

This small table-top laboratory unit, designed for continuous operation at high pressure, is the perfect equipment for high pressure processing of nanoparticles, nanodispersions, nanoemulsions, and for cell disruption. In addition, it can be successfully used for processing dairy products, fruit juices, liquid food, food additives and ingredients as well as cosmetic and chemical products. Tests can be run even with small sample volumes, and the results are comparable with those achieved on bigger size machines.

COMPRESSION BLOCK

- High grade and high performances Super Duplex stainless steel
- Designed to ensure the maximum stress resistance to maximise the performances and reliability at high operating pressure
- Solid ceramic pumping piston
- Specially designed packing that avoid the needs for lubrication water
- Suction ball valve (PVB) in ceramic, with replaceable suction valve seat in AISI 630
- High precision pressure transducer with 4-20 mA signal
- Tungsten carbide as option

HOMOGENIZING VALVE

- Reversible wear parts in tungsten carbide, ceramic as option
- Manual pressure adjustment by means of a hand-wheel
- Second stage homogenizing valve group applied as standard
- Allow front/upwards/downwards outlet to match with plant piping layout

PRODUCT INLET/OUTLET

- Tri-Clamp™ connections supplied for inline installation
- No feeding pump is needed (for product viscosity up to 1000 cP)

POWER END

- Three phase motor, suitable for variable speed drive
- Camshaft drive system and maintenance-free grease lubrication

CASING

- Made in ABS, completely removable for maintenance and cleaning
- High quality stainless steel base frame
- Adjustable anti-vibration rubber feet

CONTROL PANEL

- Touch screen display for machine control
- Start/stop drive control
- Pressure trend diagram visualization
- Built-in safety protection against overpressure



PandaPLUS 1000

DIMENSIONAL DRAWING

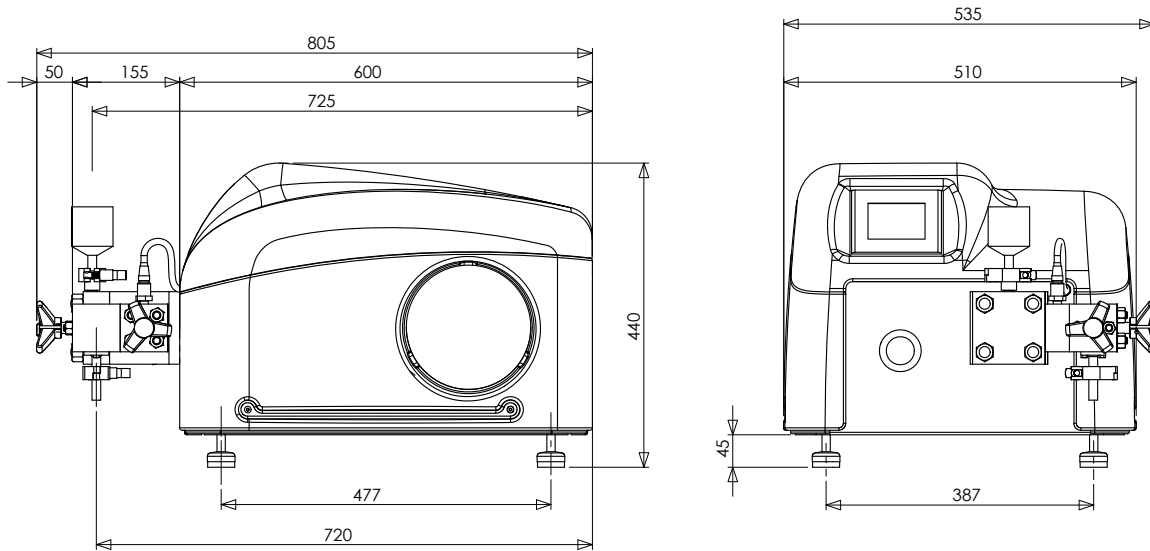

measure in mm

The compact design of PandaPLUS offers an easy installation, use and maintenance. Thanks to special material selection and liquid end design, it is suitable for abrasive and viscous products and offers reliable use of high pressure energy for new production process development and optimized product formulation. In its standard configuration, it features a touch panel for easy control of all machine functions.

DESIGN FEATURES AND PERFORMANCES

Max operating pressure 1000 bar

Three-phase motor 2.2 kW
 200 V / 50 Hz
 220 V / 50 - 60 Hz
 400 V / 50 - 60 Hz
 460 V / 60 Hz

Weight 105 Kg

Dimensions mm W 540 x H 440 x L 810

Connections in/out 1/2" Tri-Clamp™

Minimum sample volume 40 ml

Sound pressure level < 69 dB (A)

Suitable for CIP/SIP

OPTIONS

- Electropolished version (Ra 0.5 µm)
- FDA approved gaskets and cGMP documentation
- In-line product cooler
- Pneumatic pusher for feeding hopper

FLOW RATE (l/h)	PRESSURE (bar)	ELETRICAL SUPPLY (Hz)
20 l/h	1000 bar	50 Hz
24 l/h	1000 bar	60 Hz

Technical specifications are not mandatory and subject to change without notice



GEA Mechanical Equipment
GEA Niro Soavi S.p.A.

Via A. M. Da Erba Edoari, 29 - I 43123 Parma (Italy)
 Phone + 39 0521 965411 Fax +39 0521 242819
 Info.GeaNiroSoavi@geagroup.com www.niro-soavi.com