

P A C K I N G T E C H N O L O G Y





AVAPAC™ PACKING TECHNOLOGY



Avapac™'s reputation as an unparalleled provider of hygienic packing technology has been built through industry experience, engineering excellence and the integrity of its personnel.

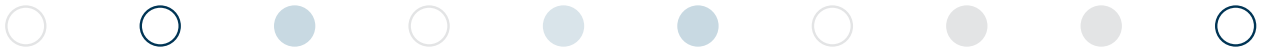

AVAPAC™ provides a standard range of bag filling equipment and systems that complements clients' needs. A high technical and hygienic standard enables customers to produce consistently high quality products across constantly changing industries.

"the standard by which others are measured"



This strength of product range, engineering expertise and worldwide networking enables AVAPAC™ to enhance existing products by continuous development. It can also provide increased output as well as simpler (yet more robust) systems for low speed applications.

Our knowledge and experience will help you employ the optimum solution. With our worldwide presence and a specialist team of engineers and technicians, we can also offer the best advice.

This brochure demonstrates our competence, coupled with the value of comprehensive advice from our technicians and engineers.

Our experience has shaped our knowledge to assist you by providing economically and technically perfect solutions with the most appropriate product.

Success through competence and quality, intensive and innovative development, and research have led to a comprehensive know-how, acquired over decades.

The global scale of our company ensures worldwide availability of our products and service.

We invite you to enjoy the benefits of AVAPAC™'s experience and expertise for yourself.





Products

AVAPAC™ designs and manufactures hygienic packing systems for a wide range of powders, including:

- Whole Milk
- WPC
- Skim Milk
- Buttermilk
- Fat Filled Whey
- Caseinates
- Lactate
- Hydrolysed Yeast Calcium Lactate
- Permeates
- Baby Food
- Hydrolysed Whey Proteins
- Functional Food Compounds
- Coffee Whitener
- Hydrolysed Corn Starch
- Bakery Mixes
- Cocoa Powders
- Soya Bean Bases
- Tomato Powders
- Soup Bases
- Pharmaceutical Compounds
- Stearic Acids
- Acrylic Resins

AVAPAC™ Carousel Bag Fillers

Carousel Bag Fillers are designed to meet the demands of the dairy and food industries for hygienic packing lines. Their capacity matches very large powder manufacturing plants.

The design is carousel based with bag heads passing four operation stations:

- Bag loading
- Bulk powder filling
- De-aeration of surplus air from powder
- Bag vibration / compacting

After the bags are released from the bag heads, they are conveyed to the powder filling process and prepared for the next stations in the packing line.

The bulk filling operation uses the AVAPAC™ bottom-up filling system, minimising the introduction of false air into the powder and powder emission to the environment. Dust extraction facilities further contribute to a clean packing area.

Where sensitive high fat powders or similar are packed, the option of packing in a modified atmosphere can be ordered. This facility can be added at a later stage to the Carousel Bag Fillers.

An optional powder sampling system, integrated with the control system, allows the continuous monitoring of powder quality.

Twinhead Carousel 1800

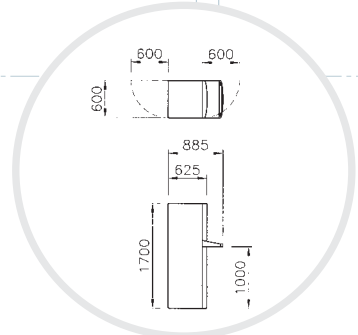
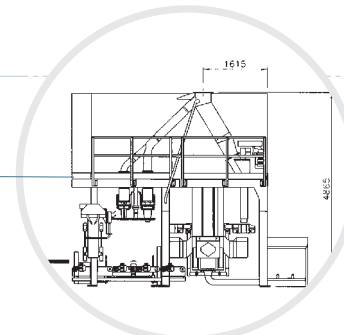
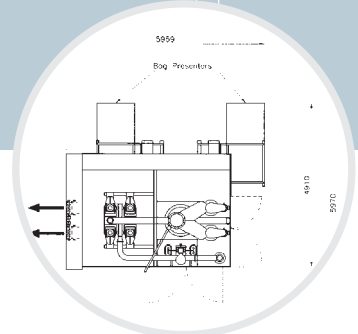
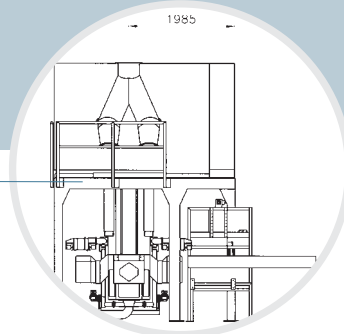

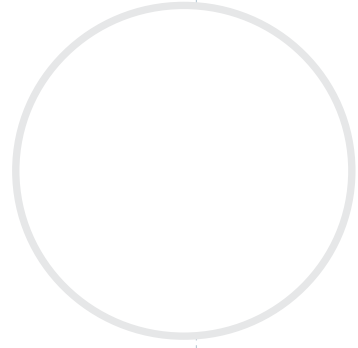
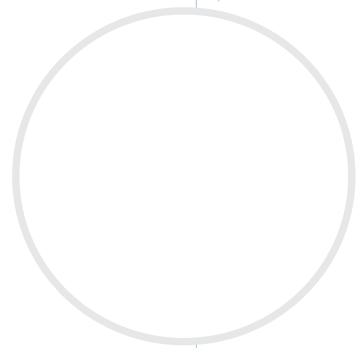
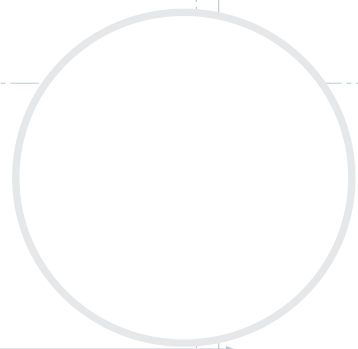
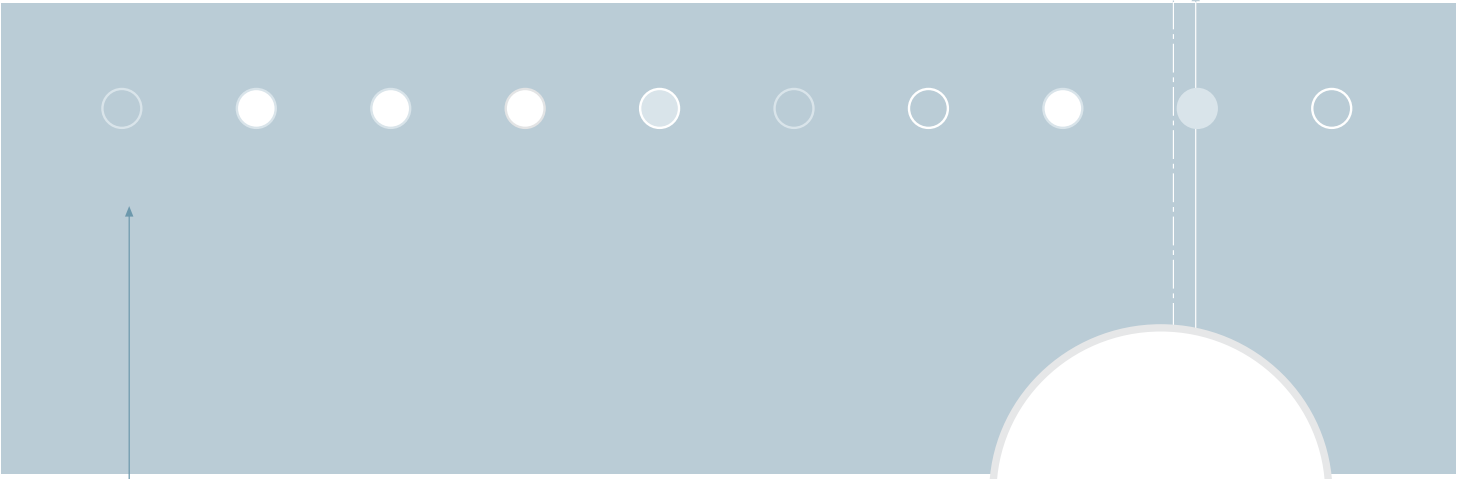

AVAPAC™ Inline Bag Fillers

Where medium packing rates, hygienic design and extremely high accuracy are required, the Inline Bag Fillers are selected for the dairy and food industries.

Inline Bag Fillers offer a flexible and reliable straight line packing process passing the following stations:

- Bag loading
- Bulk powder filling
- De-aeration of surplus air from powder
- Top-up filling
- Optional bag vibration / compacting

The Inline-600 provides the top-up filling through one auger while the Inline-800 uses two top-up augers to increase the speed of the filling process, while maintaining accuracy.

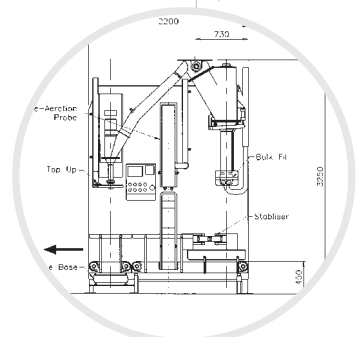
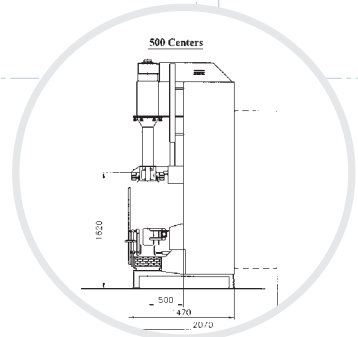
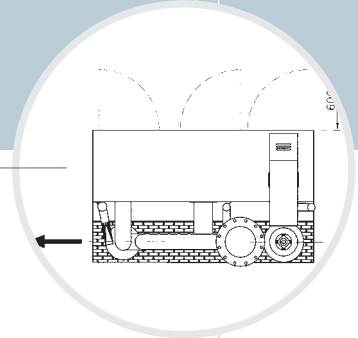

Bag Filler

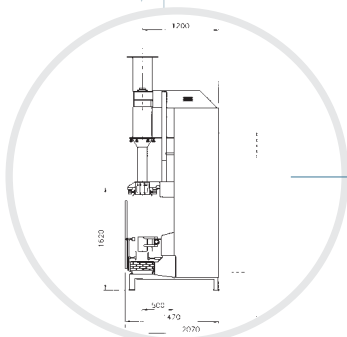
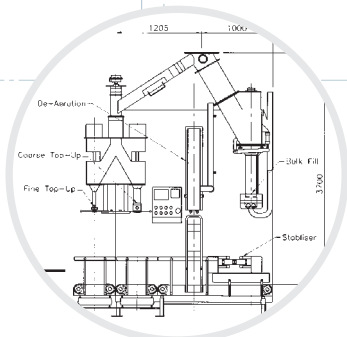
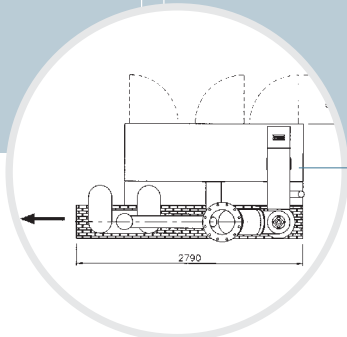

InLine 800 Bag Filler

The bulk powder filling uses the AVAPAC™ bottom-up filling system, minimising the introduction of false air into the powder, and powder emission to the environment. Optional dust extraction facilities will further contribute to a clean packing area.

Where sensitive high fat powders or similar are packed, the option of packing in a modified atmosphere is available.

An optional powder sampling system, integrated with the control system, allows continuous monitoring of powder quality.

The AVAPAC™ InLine-600 Bag Filler can pack up to 6,000 kgs of powder per hour (3-4 25kg bags per minute) and the AVAPAC™ InLine-800 can pack up to 8,000 kgs of powder per hour (5-5.5 25kg bags per min).

InLine Bag Fillers include an integral MCC Panel with main PLC and an Operator Control Station allowing minimal operator intervention.

founded by a
group of
innovative
New Zealand
based
engineers

AVAPAC™ Single Head 450 Bag Filler

Single Head-450 Bag Fillers are designed for the manufacturer of dairy and food powders where high capacity and accuracy is not a major requirement.

The Single Head-450 Bag Filler, basic offers a flexible and reliable straight line packing process passing the following operation stations:

- Bag loading (manual or auto)
- Bulk powder filling and topping-up

Single Head-450 Bag Filler with de-aeration system also offers:

- De-aeration of surplus air from powder
- Optional bag vibration /compacting

Top-up filling of the bag is accomplished by using the main auger for a secondary-filling step.

The bulk filling operation uses the AVAPAC™ bottom-up filling system, minimising the introduction of false air into the powder, and powder emission to the environment. Optional dust extraction facilities further contribute to a clean packing area.

Where sensitive high fat powders or similar are packed, the option of packing in modified atmosphere is available.

The AVAPAC™ Single Head-450 Bag Filler can pack up to 4,500 kgs of powder per hour (2-3 25kg bags per minute).

An optional powder sampling system integrated with the control system allows continuous monitoring of powder quality.

Single Head-450 Bag Fillers include an MCC Panel with main PLC and an Operator Control Station.

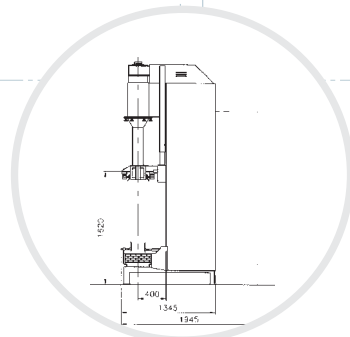
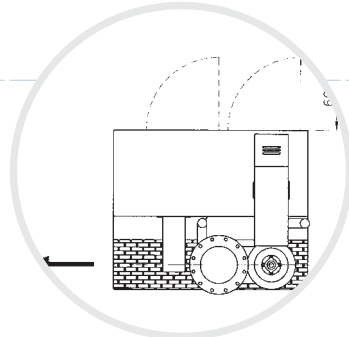
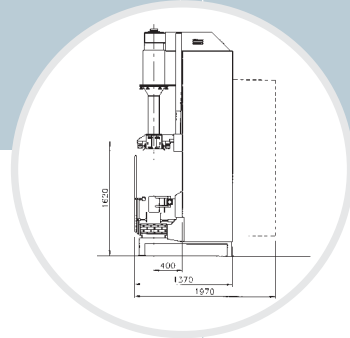
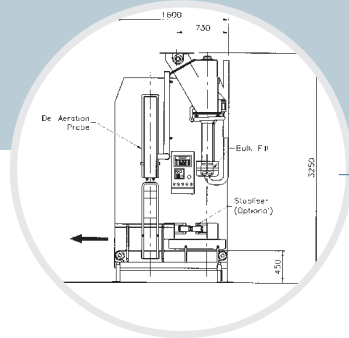

Single Head 450 Bag Filler

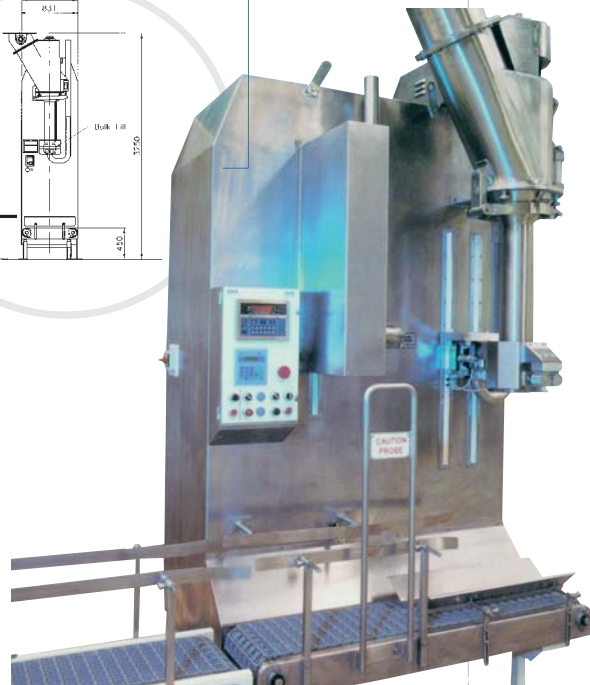
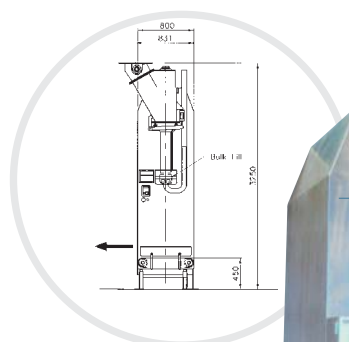

AVAPAC™ Compact-300 Bag Filler

The Compact-300 Bag Filler is designed for use where limited powder production must be packed under hygienic conditions.

The Compact-300 Bag Filler offers a flexible and reliable straight line packing process passing the following operation stations:

- Manual bag loading
- Bulk powder filling and topping-up

Top-up filling of the bag is accomplished by using the main auger for a secondary-filling step.

Optional dust extraction facilities contribute to a clean packing area.

The AVAPAC™ Compact-300 Bag Filler packs up to 3,000 kgs of powder per hour (1-2 25kg bags per min).

The Compact-300 Bag Filler includes an MCC Panel with main PLC and an Operator Control.

Compact 300 Bag Filler

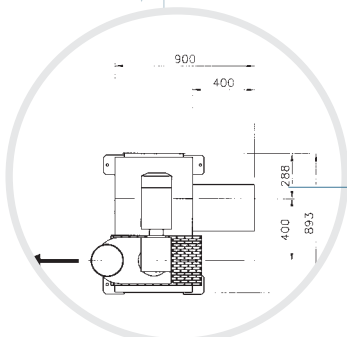
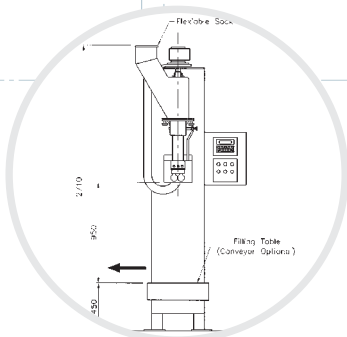
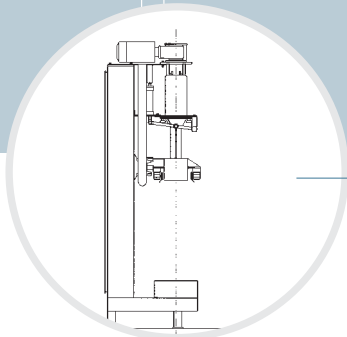

AVAPAC™ Bag Presenter

The Bag Presenter is designed for use with the different AVAPAC™ bag fillers.

Features include automatic:

- De-stacking
- Bag opening
- Loading of the bags onto the bag filler head

Includes a pneumatically operated pull down and presentation mechanism.

The Bag Presenter is capable of handling a range of bag lengths and widths where the plastic liner is an integral part of the bag.

Features include:

Simple bag length adjustment and an integrated PLC Control Panel.

In-house engineer designed and custom manufactured on site

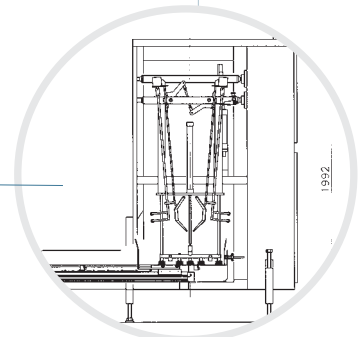
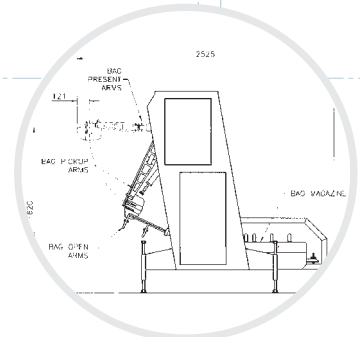
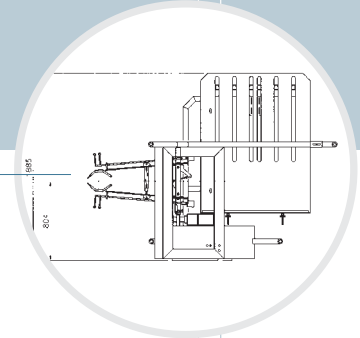

Bag Presenter

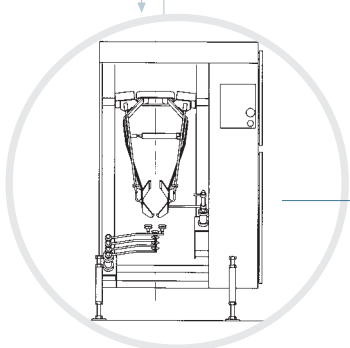
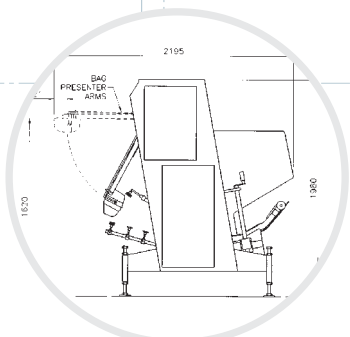
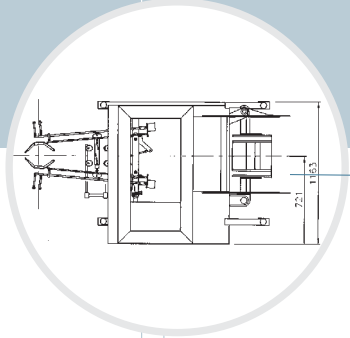

Bag Presenter vertical feed

Special purpose
built bag
presenters are
built for the
Carousel 1800



AVAPAC™ Heat Sealer

The continuous motion Heat Sealer is a precise and reliable bag-closing machine used in food and dairy packing lines throughout the world.

The Heat Sealer has three automatically operated activity stations:

- Bag top leveling
- Bag sealing
- Bag closing

The bag is closed through the following steps:

- Bag top leveling (prepares the bag for the closing process)
- Bag seal cleaner (optional)
- Sealing of polyethylene inner liner
- Compression of seal area
- Scoring of inner liner for easy release of inner pouch
- Crimping / pre-folding
- Glue reactivating
- Final folding
- Final compression

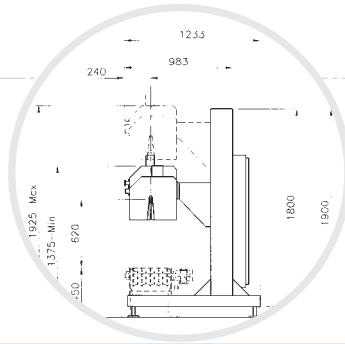

Heat Sealer

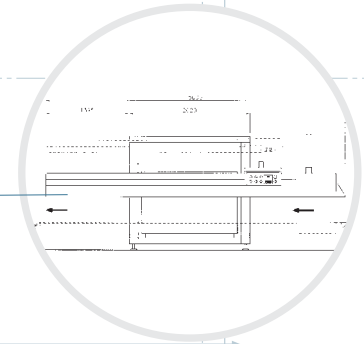
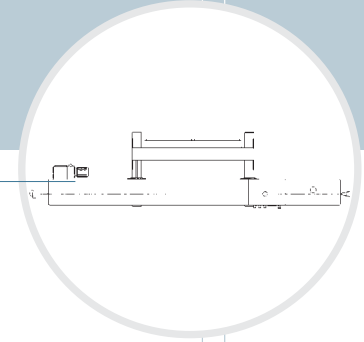

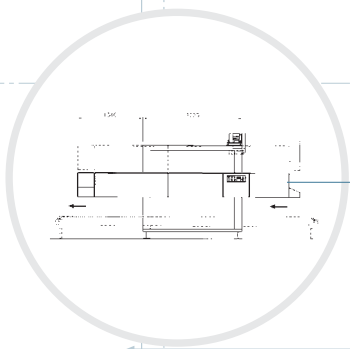
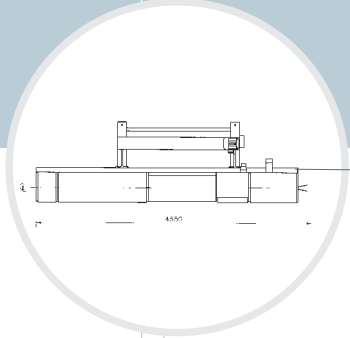

Stratapac Heat Sealer

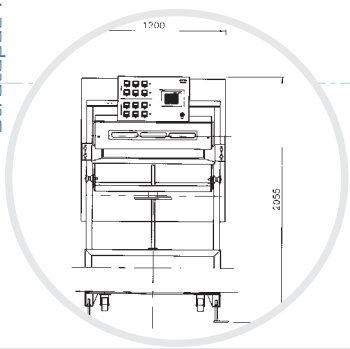

The unit is adjustable for a wide range of bag sizes and types which have a polyethylene inner liner.

Provision for dust extraction is included.

Where the powder dust from the filling process may adhere to the liner inner surface, the optional feature of a bag mouth cleaning system is recommended.

The Heat Sealer is fully PLC controlled with convenient operator interface.

For smaller applications where manual intervention is possible, the Static Heat Sealer can be selected.

electrical components are internationally recognised for their quality and advanced technology

Stratapac™ Heatsealer



AVAPAC™ Bag Handling Equipment

AVAPAC™ packing lines are configured to meet the specific requirements of the customer.

The 'heart' of each line will always be the Bag Filler and Heat Sealer (see previous section).

The ancillary units needed for the handling of the bags after the closing process are important parts of the AVAPAC™ supply.

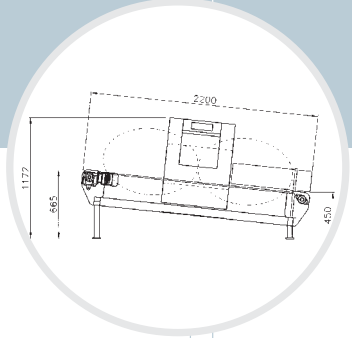
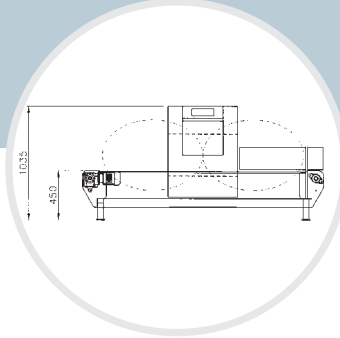

metal detector-conveyor incline

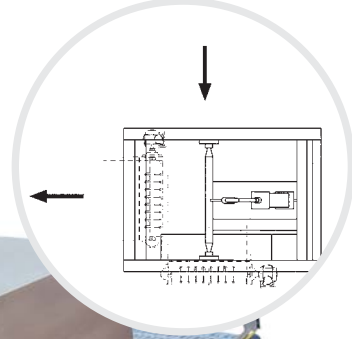
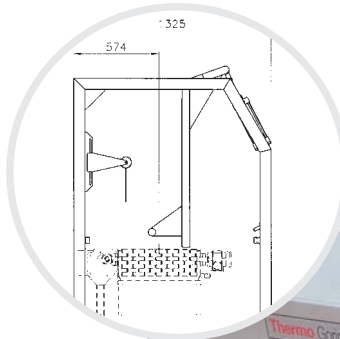
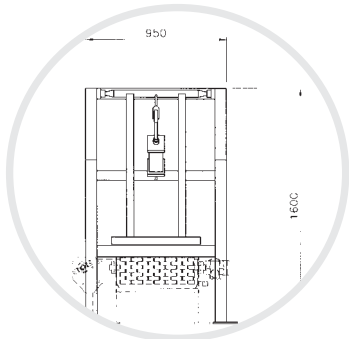
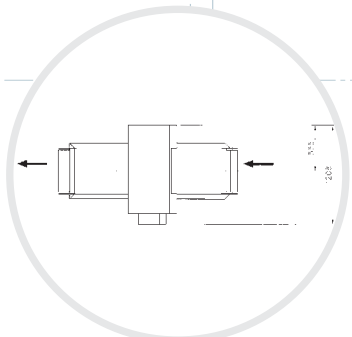
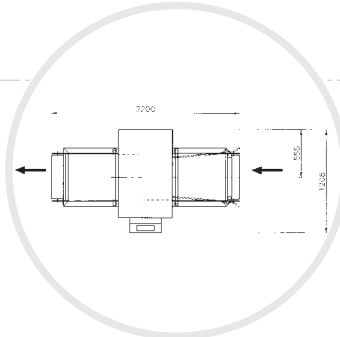

Metal Detector



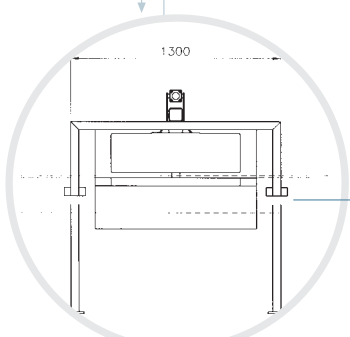
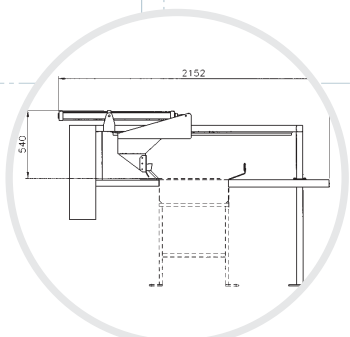
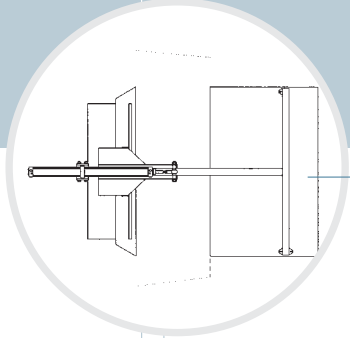

Bag Rejector

Bag quality control units:

- **Metal Detector**, adjustable, for detecting possible metal fragments in the powder.
- **Check Weigher** for monitoring and recording the actual weight of the sealed bags. Adjustable acceptance criteria.
- **Bag Reject Unit**, integrated with the Metal Detector and the Check Weigher, or either one individually. Pushes rejected bags off line.



Bag Rejector

The **Bag Turner** gently changes the bag position from vertical to horizontal position with the selected orientation (top or bottom first).

The **Bag Kicker** is selected when the packing line conveyor path must turn 90°. The Bag Kicker tips and then gently pushes the bag 90° to the correct orientation (top or bottom first).

The **Bag Flattener**, mounted above the bag conveyor, prepares the bag for stable palletising by means of powered rollers.



Bag Flattener



Bag Kicker

Bag Turner

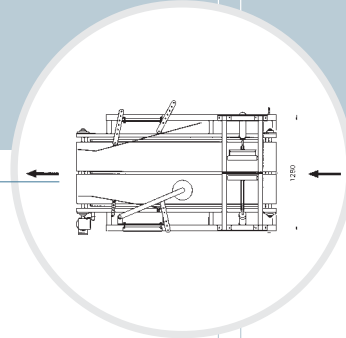

Bag Flattener

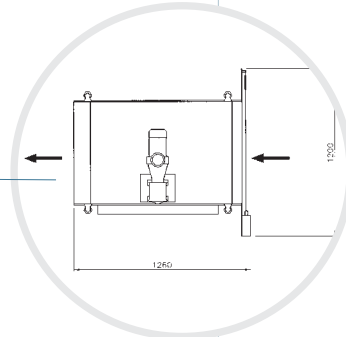
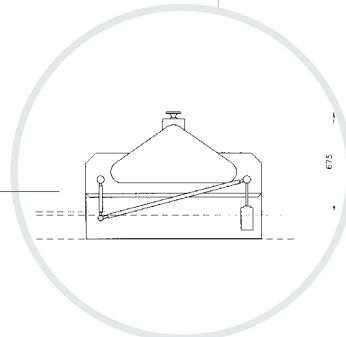
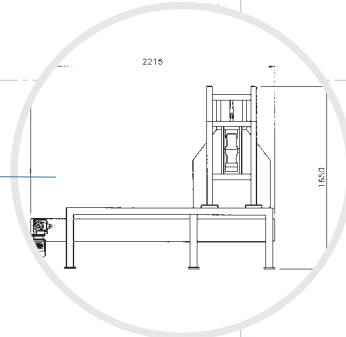

The ink-jet **Bag Coder**, mounted on a moveable support on the side panels of the bag conveyor, will continuously print the selected code on the passing bags.

AVAPAC™ sends a team to new owners to assist with assembly of each machine



Additional AVAPAC™ features and options

Dust Collection

Effective dust extraction is an excellent feature of AVAPAC™ equipment. This is due to the fact that during bulk filling the small amount of dust generated is collected before it can escape. This is done through collection points on the bag heads. At all other stations such as De-aeration, Top-up and Neck Stretcher, there are dedicated dust collection points to capture any dust before it escapes to an uncontrolled area.

Powder Sampler System

The AVAPAC™ Powder Sampler system allows samples of powder to be taken as required. The features of the powder sampler are as follows:

- Metering screw for sample collection, with adjustable speed regulation by means of mechanical variator.
- Adjustable start / stop set points for collecting varying sample sizes.
- The frequency of sampling can be varied over a sampling period to collect a sample every bag, every three bags, or whatever is required.

Divertor

- Two outlet pipes with adapter for collection bag.

Station Divertor

- Automatic change to empty collection bag when set point (e.g. full pallet or batch) for collection is obtained. Manual intervention possible.
- Manual change of collection bags
- Control from main Control System
- Material: Stainless steel AISI 304



Additional AVAPAC™ features and options

The AVAPAC™ Statistical Package provides two essential features:

Display of Statistical Information

Logging of Statistical Information

There are two examples of reports for the Inline-600 and Inline-800 Bag Fillers on the next page. Specific requirements can be accommodated, and upon receipt of the client's specification, a quotation can be generated to meet your requirements.

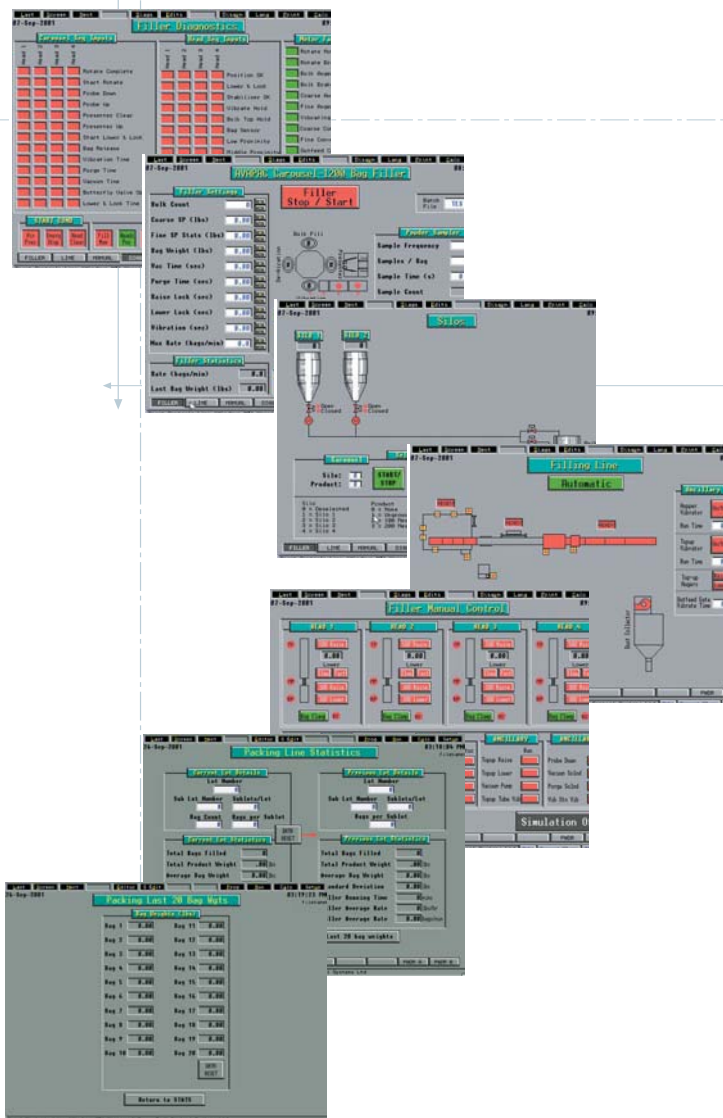

AVAPAC™ Production Statistics

The full version of the AVAPAC™ Statistical Package option is available when the Bag Filler has been upgraded to Smart Controls™. Smart Controls™ is a PC based HMI (Human Machine Interface) that can provide fast and efficient display of individual bag weights and daily production figures.

This package comes as standard on the Carousel 1200 Bag Filler, but is an option on the Inline 600 and Inline 800 fillers.

Additional AVAPAC™ features and options

Report Example 1:

15-08-00.a1

Standard format (units = grams)	16:26:10,	25005,	1
The logged data appears is listed in three columns:	16:26:25,	25000,	1
Column 1 Time stamp when bag was filled (hr:min:sec)	16:26:38,	25015,	1
Column 2 Bag net weight (grams)	16:26:52,	25010,	1
Column 3 Shift Number (or Lot No etc)	16:27:07,	25005,	1
	16:27:21,	25005,	1
	16:27:36,	25005,	1

Report Example 2:

16:27:50, 25000, 1
16:28:04, 25010, 1

Customised format (units = pounds)	16:27:50,	25000,	1
The logged data appears is listed in nine columns:	16:28:04,	25010,	1
Column 1 Lot Number			
Column 2 Sub Lot Number			
Column 3 Start time (hr:min:sec)			
Column 4 Sub Lot - Average Bag Weight (lbs)			
Column 5 Sub Lot - Total weight (lbs)			
Column 6 Sub Lot - Total number of bags filled			
Column 7 Sub Lot - Standard Deviation (lbs)			
Column 8 Bag Packing Rate			
Column 9 Days Production – Standard Deviation (lbs)			

Options

1	1	00:12:56	55.03	19,810	360	0.014	434	0.014
1	2	00:52:26	55.01	19,803	360	0.013	389	0.011
1	3	01:22:44	55.04	19,814	360	0.024	278	0.012
1	4	02:12:36	55.03	19,810	360	0.010	460	0.010
1	5	02:42:12	55.00	19,800	360	0.014	389	0.016
1	6	03:25:32	55.01	19,803	360	0.034	378	0.015
2	1	04:02:56	55.03	19,810	360	0.012	367	0.018
2	2	04:52:15	55.02	19,807	360	0.017	428	0.025
2	3	05:22:56	55.05	19,818	360	0.018	453	0.026
2	4	06:12:12	55.01	19,803	360	0.011	419	0.013
2	5	06:53:14	55.02	19,807	360	0.012	398	0.024
2	6	07:15:36	55.04	19,814	360	0.010	378	0.010
3	1	08:08:00	55.03	19,810	360	0.016	386	0.014
3	2	08:54:06	55.03	19,810	360	0.015	402	0.034
3	3	09:27:56	55.02	19,807	360	0.018	308	0.012
3	4	09:12:50	55.02	19,807	360	0.025	459	0.017
			55.0244	316,940	5760	395.375		

Additional AVAPAC™ features and options

The flexibility of our technology allows for the integration of components, which further assists AVAPAC™ in working with alternate suppliers to produce customers solutions.



Additional AVAPAC™ features and options

AVAPAC™ Statistics Package – limited version

A limited version of the full AVAPAC™ Statistics Package is used when statistical data is required but when the Packing Line has not been upgraded to Smart Controls™. The essential difference is that the limited version does not have a PC and therefore is unable to log data or display all the current information simultaneously on a monitor.

Displayed Statistical Information

Statistical information is displayed on a small LCD display, usually only one field at a time but this will depend on the type of operator interface used.

Logged Statistical Information

Statistical information is unable to be logged to a hard disk as there is no longer a PC. By upgrading the Packing Line PLC to have Ethernet connectivity, this statistical information is available to be read continuously into a remote PC for report generation.

AVAPAC™ Packing Line Control System

In some instances the AVAPAC™ packing line includes an MCC (motor control cabinet) panel, which allows the main PLC to integrate the various machine functions of the entire packing line, allowing for control of the entire system. All systems are interlocked for safe and correct operation.

The operator control cabinet comprises the following componentry:

- Main switch
- Digital controller(s) / indicator(s)
- On/off switches for motors
- Push buttons,
- Alarms, and pilot lamp

Diagnostics

The Diagnostics Function stores such data as 'Alarm Messages' and input/output status. The control software assumes that all equipment is correctly functioning and on that basis logical decisions are made. If any part of the equipment malfunctions, the plant will stop and an alarm message will appear on the screen. The messages appear in a red window and are recorded as alarms in the display alarm files.

Additional AVAPAC™ features and options

Hazardous Zoning

AVAPAC™ has had experience with implementing hazardous zoning in several of our installations.

Equipment for potentially explosive atmospheres (optional feature):

Directive 94/9/EC of the European Parliament and the Council of 23 March 1994 on the approximation of the laws of the Member States concerning equipment and protective systems intended for use in potentially explosive atmospheres.

Cleaning

The AVAPAC™ Bag Filling equipment has been designed for easy dismantling to expose critical hygiene areas. The following information is a general description of the areas most likely to require regular cleaning, especially when changing products and cross contamination is not desirable:

• Bulk Fill Spout and Bulk Fill Auger

These can be easily removed exposing the internal surface of the Bulk Fill Hopper for cleaning. The Valve Spout and Auger can then be wet washed if required. The Bag Clamps can also be easily removed for cleaning when, and if, wet washing is required. Normally dry cleaning in place is recommended.

• Top-Up Spout and Augers

These can be removed in a similar manner to the Bulk Fill Spout and auger also exposing product contact areas within the machine. **Please Note:** The screw seals are cleansed, inspected and, if necessary, replaced when the screws are removed for cleaning.

• De-aeration Probes

These can be removed and cleaned by blocking one end and flushing out by forcing near boiling water through the filter material from the inside. This will force any contamination outward. To dry, place the probes vertically in a sterile low humidity environment until completely dry.

• Top-Up Conveyors

These can also be lifted from normal working position for general cleaning and maintenance when required. Generally the unit can be cleaned by air jet or wiping to achieve day-to-day cleanliness (more detailed dismantling and cleaning information is available in the operations manual). It is important to keep the equipment clean at all times. A thorough and regular cleaning schedule will help ensure top performance from all AVAPAC™ equipment.

AVAPAC™ is committed to the highest technical and hygienic standards

Metering Methods

AVAPAC™ offers three metering options for its hygienic powder packing equipment:

- Volumetric
- Weighting
- Final Topping

Final Topping

This method is used only if final weight, after auger is stopped and scale settle time expired, is slightly under-weighted. The machine will top-up the bag by opening the Auger Butterfly Valve without starting the auger and allow powder to drop in the bag.

The amount of powder is controlled by:

- TIMER
Valve open time
- COUNTER
Number of valve flipping

Volumetric

Filling by Volume controlled by:

- TIMER
Auger run time (at set speed)
- COUNTER
Set number of revolutions of auger (at set speed)

Weighting

Filling by Weight controlled by:

- SCALE
Fast Filling (at set speed) up to the predetermined weight
- SCALE
Slow Filling (at set speed) up to the final weight



Directives and Standards

We have a number of international subsidiary companies and we supply to more than 50 countries worldwide. But more important to our customers is the fact that we understand their needs. We make it our business to anticipate the individual regulations of every country in which we trade, regarding packaging, import/export documentation, etc.

It is important to understand the legislation affecting the food industry to ensure the appropriate requirements and special demands of this industry can be met, thus avoiding unnecessary risks.

Following is a short summary of the standards and directives that are applicable to powder packing machinery.

Machinery directives:

89/392/EEC

91/368/EEC

93/44/EEC

Electromagnetic compatibility directives:

89/336/EEC

92/31/EEC

Low voltage directive:

73/23/EEC

3-A Sanitary Standards and 3-A Accepted Practices, E-3-A Sanitary Standards for the International Association of Milk, Food and Environmental Sanitarians, Inc. (IAMFES).

"Thinking globally,
operating globally"



AVAPAC™ Services

In-house Engineering

Listening and understanding lies at the root of innovation. For this reason, we give close customer communication the highest priority. To this extent our on-site development and engineering facilities allow us to be innovative in developing customised solutions. We are your partner in every respect and will oversee your project from beginning to end.

With you, our team of qualified and experienced engineers and technicians will develop detailed specifications for your requirements, incorporating state-of-the-art technology. We will help you select the best process for your product. The resulting equipment will meet all requirements regarding cost-effectiveness, hygiene and product quality.

The international dairy market is constantly developing to fulfil new consumer demands and we aim to meet our customers' ever changing requirements.

Spare Parts & Shipping

AVAPAC™ machinery is packaged, palletised and shrink-wrapped for clean and safe delivery. Our storage facilities meet the most stringent hygiene requirements.

AVAPAC™ spare parts are packaged with liquid polyurethane, which quickly expands and solidifies to form a custom-fit protective packaging material for our parts. This modern method of packaging guarantees our clients receive their parts in optimum condition.

Our computer network links details of everything we produce and every item is tracked through this system. The safety aspect of this total traceability gives our customers peace of mind.

Installation, Commissioning and Operator Training

Our employees are the key to our success. Their knowledge and abilities, their motivation and flexibility give AVAPAC™ its competitive strength. This strength includes a team of experienced engineers and technicians that will install and commission your equipment to the highest standard. We are also pleased to offer our knowledge and experience to your employees through customised training programmes.

Service Contracts

To address a customer's real needs, we provide solutions that include people and service to support our products. We offer service contracts to our clients whereby our team of experienced engineers and technicians will service and maintain your equipment to ensure a continuum of optimum performance.

A blend of quality & experience

Pure, natural, fresh and healthy is what consumers expect from dairy and food products. A blend of quality and experience is an AVAPAC™ system technology that enables us to meet these expectations.

We have been supplying hygienic powder packing machinery worldwide for over 30 years. Our commitment to our customers and anticipating their needs is our basic strategy for the future. Our aim is to get it right every time. The right systems technology for the right product materials at the right price, delivered to the right place at the right time.

Technical Specifications

Machine Specifications

Machine	Nominal Packing Rate Bags Per Hour	Max Bag Length mm	Min Bag Length mm	Max Bag Width mm	Min Bag Width mm	Machine Height to inlet mm	Machine Depth mm	Machine Length mm	Shipping Weight kg	Noise Emission less than Db(a)
Carousel-1800 +NS	720	950	750	600	480	4860	3485	4940	11500	85
Carousel-1200 +NS	480	950	750	600	480	3810	2650	3980	4900	85
Carousel-1200	480	950	750	600	480	3810	2650	3980	4600	85
Inline-800	320	950	750	600	480	3695	1400	2790	1500	85
Inline-600	240	950	750	600	480	3250	1400	2200	1350	85
SH-450 + P + Stabiliser & Vibrator	180	950	750	600	480	3250	1300	1700	900	85
SH-450 + P	180	950	750	600	480	3250	1300	1700	850	85
SH-450	180	950	750	600	480	3250	1300	1070	800	85
Compact-300	120	950	750	600	480	2700	905	1055	400	85
Twin Heat Sealer	720	950	750	600	480	2350	1600	7320	3200	85
Heat Sealer	600	950	750	600	480	2100	1200	5000	1400	85
Heat Sealer - Stratapac Automatic	600	950	750	600	480	2150	1320	4480	1650	85
Heat Sealer - Stratapac Static	600	950	750	600	480	2055	2530	1260	700	85
Bag Presenter Vertical	480	950	750	600	480	1980	2030	1160	550	85
Bag Presenter Horizontal	480	950	750	600	480	1980	2530	1890	550	85
Bag Presenter APB	480	950	750	600	480	1945	1600	4170	600	85
Neck Stretcher	480	950	750	600	480	2255	1130	790	300	85

Technical Specifications

Service Requirements

Machine	Electrical Power Kw	Average Air Consumption cubic M/Hr @6 bar	Dust Extraction cubic M/Hr @ -2kPa	Vacuum cubic M/Hr @ -90kPa	Ambient Light Level lux	Relative Humidity less than % @ 20 degrees C	Ambient Temperature deg C
Carousel-1800 +NS	25	145	4500	40	750	50	5- 40
Carousel-1200 +NS	12	180	2300	40	750	50	5- 40
Carousel-1200	12	170	1800	40	750	50	5- 40
Inline-800	8	60	825	30	750	50	5- 40
Inline-600	7	50	750	30	750	50	5- 40
SH-450 + P + Stabiliser & Vibrator	3	40	600	30	750	50	5- 40
SH-450 + P	3	30	600	30	750	50	5- 40
SH-450	3	15	260	N/A	750	50	5- 40
Compact-300	3	6	260	N/A	750	50	5- 40
Twin Heat Sealer	24	140	2300	N/A	750	50	5- 40
Heat Sealer	12	70	855	N/A	750	50	5- 40
Heat Sealer - Stratapac Automatic	12	65	850	N/A	750	50	5- 41
Heat Sealer - Stratapac Static	6	30	N/A	N/A	750	50	5- 42
Bag Presenter Vertical	0.1	25	N/A	30	750	50	5- 40
Bag Presenter Horizontal	0.1	24	N/A	30	750	50	5- 40
Bag Presenter APB	0.1	75	N/A	40	750	50	5- 40
Neck Stretcher	0.1	24	260	N/A	750	50	5- 40

Technical Specifications

Electrical Equipment Specifications

Item	Description	Make	Type	Compact-300	Single Head-450	Inline-600	Inline-800	Carousel-1200	Carousel-1800	Bag Pres - Vert	Bag Pres - Horiz	Sealer	Sealer - Strata Auto	Sealer - Strata Static	
1	PLC Hardware	Allen-Bradley	ControlLogix							•					
		Allen-Bradley	SLC 5/04					•							
		Allen-Bradley	SLC 5/03	•	•	•					•	•	•	•	
		Allen-Bradley	Micrologix	•											•
		Siemens	S7-300	•	•	•	•	•			•	•	•	•	•
2	HMI (Human Machine Interface)	InTouch	Wonderware												
		Tait Control Systems	Smart Controls					•							
		Allen-Bradley	DTAM		•	•	•						•	•	•
		Allen-Bradley	MicroView	•											
		Siemens	TP170	•	•	•	•						•	•	•
3	Personal Computer (for HMI)	Compaq	DeskPro					•	•						
	Monitor (for HMI)	Compaq	17"					•	•						
	Mouse Pointing Device	DuraPoint						•	•						
4	Variable Frequency Drives	Allen-Bradley			•	•	•	•					•	•	
		SEW Eurodrive		•					•						
5	PLC/MCC Enclosures	Rital				•	•	•	•				•	•	•
		Avalon Engineering		•	•						•	•			
6	Motor Starters	Allen-Bradley		•	•	•	•	•	•				•	•	•
7.1	Motors - ac Induction	SEW Eurodrive		•	•	•	•	•	•				•	•	
7.2	Motors - ac Servo	SEW Eurodrive							•						
8	DC Power Supplies	Weidmuller	Switch Mode	•	•	•	•	•	•	•	•	•	•	•	
9	Photo Electric Sensors	Allen-Bradley			•	•	•	•	•				•	•	
		Sick							•						

Technical Specifications

Electrical Equipment Specifications

Item	Description	Make	Type	Compact-300	Single Head-450	Inline-600	Inline-800	Carousel-1200	Carousel-1800	Bag Pres - Vert	Bag Pres - Horiz	Sealer	Sealer - Strata Auto	Sealer - Strata Static
10	Proximity sensors	Allen-Bradley		•	•	•	•	•	•	•	•	•	•	•
11	Reed Switches	SMC		•	•	•	•	•	•	•	•	•	•	•
12	Control Switches & Panels	Allen-Bradley		•	•	•	•	•	•	•	•	•	•	•
13	Terminals - rail mounted	Weidmuller		•	•	•	•	•	•	•	•	•	•	•
14	Cable Marking	Raychem Shrinkmark		•	•	•	•	•	•	•	•	•	•	•
15	Electrical Drawings	AutoCad LT		•	•	•	•	•	•	•	•	•	•	•
16	Electrical Symbols	IEC 617		•	•	•	•	•	•	•	•	•	•	•
17	Weigh Scales Load Cells	Rice Lake							•	•				
		Mettler Todedo												
		Bilanciai		•	•	•	•							
18	Weigh Scale Indicators	Rice Lake		•	•									
		Mettler Todedo				•	•	•	•					
		Bilanciai		•	•	•	•							
19	Safety switches	Guardmaster			•	•	•	•	•	•	•			
20	Miniature Circuit Breakers	Merlin Gerin	4.5kA	•	•	•	•	•	•	•	•	•	•	•
21	Heat sealing elements	Hibar									•	•	•	
22	Thermocouples	Hibar	J type								•	•	•	
23	Solenoid & Process Valves	SMC		•	•	•	•	•	•	•	•	•	•	•
24	Pneumatic Cylinders	SMC												
25.1	Relays - PLC interface	Weidmuller	EA73006 24Vdc coil	•	•	•	•	•	•	•	•	•	•	•
25.2	Relays - general purpose	Omron	LY2/GR2 110/230Vac coil	•	•	•	•	•	•	•	•	•	•	•
26	Vacuum Pump	Rieschle			•	•	•	•	•					
27	Conveyor Belt	KVP		•	•	•	•	•	•			•	•	

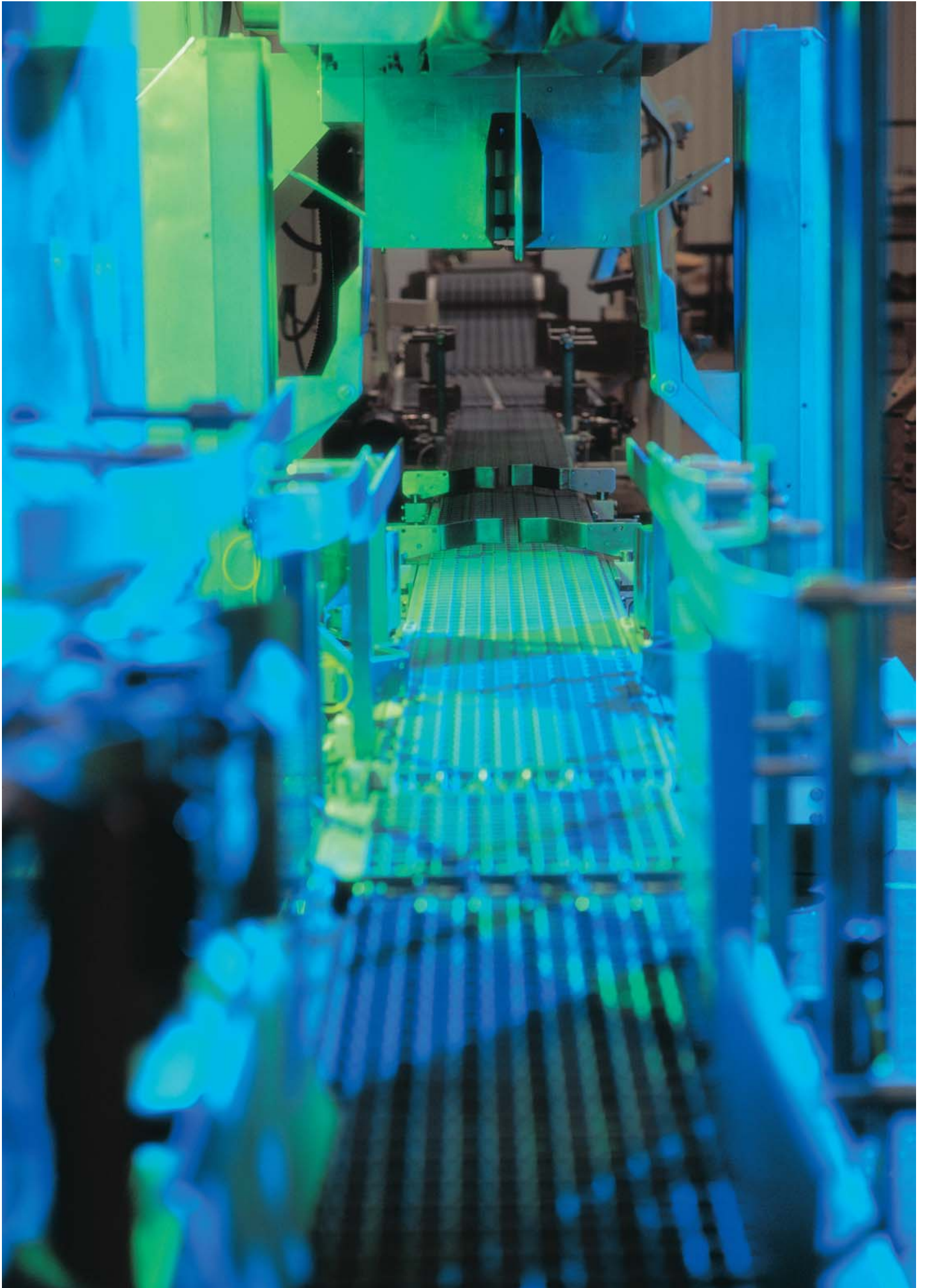

AVAPAC™ Contacts

AVALON ENGINEERING LTD

NEW ZEALAND

12-18 Foreman Road
PO Box 10266
Te Rapa
Hamilton
New Zealand

Telephone: +64-7-849-3414
Facsimile: +64-7-849-3494
E-mail: info@avapac.co.nz

SALES & SERVICE - EUROPE

Niro BV
Hoogveld 16
5431 NW Cuijk
PO Box 324
5430 AH Cuijk
Netherlands

Telephone: +31-485-396-811
Facsimile: +31-485-313-446
E-mail: info@avapac.co.nz

SALES & SERVICE - USA

Niro Inc
1600 O'Keefe Road
Hudson
Wisconsin 54016
United States of America

Telephone: +1-715-386-9371
Facsimile: +1-715-386-9376
E-mail: info@avapac.co.nz

Continued development ensures continued leadership and continued customer satisfaction

**AVAPAC™
Carousel Bag Filler**

The Carousel Bag Filler is a fully automatic unit capable of packing 25kg bags at a rate of up to 9 bags per minute at less than 10 grams STD.

Modified atmosphere packing options are available for most packers

Neck Stretcher

Heat Sealer Conveyor

Heat Sealer with Bag Leveller

Metal Detector

Reject Mechanism

Bag Turner

Check Weigher

Coding Unit

**AVAPAC™
Single Head Bag Filler with Probe**

The Single Head Bag filler is capable of packing 25kg bags at a rate of up to 4 bags per minute at 50gms STD.

**AVAPAC™
Single Head Bag Filler**

The Single Head Bag Filler is capable of packing up to 4 bags per minute at 50gms STD.

**AVAPAC™
Inline Bag Filler**

The Inline Bag Filler is a fully automatic unit capable of packing 25kg bags at a rate of up to 6 bags per minute at 15 grams STD.

